

HMC All Electric, High Speed Two-Saw Trimmer

From the company that introduced you to the all electric carriage, debarker and carriage drive now brings you the all electric, High-Speed Two-Saw Trimmer.

- **Fast Production - Saw Sets In Excess Of 6FT Per Second!**
- **Accurate • Reliable • Programmable Setworks**
- **Variable Speed Electric Vector Drive • No Oil Needed**

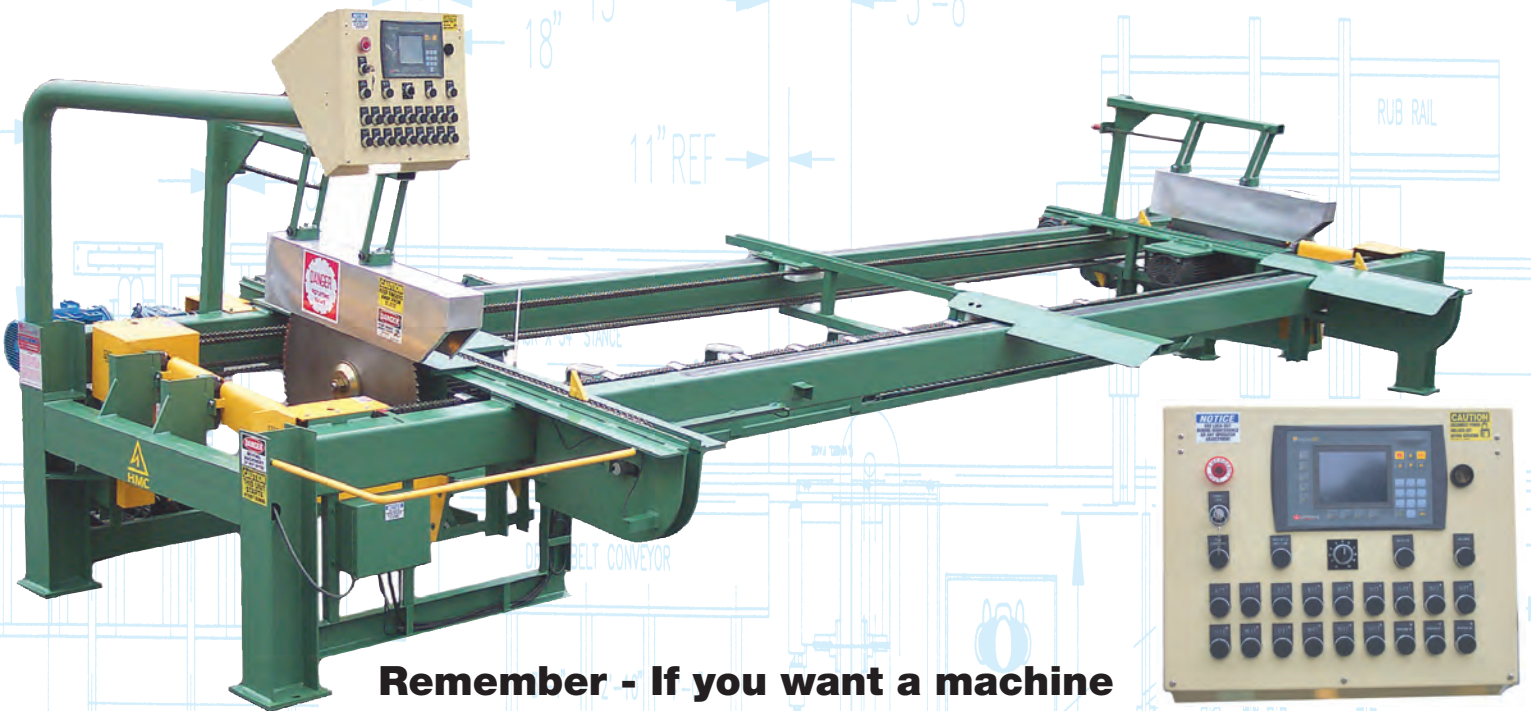

Remember - If you want a machine that performs like an HMC, you have to get the original!

Over 60 years experience goes into every piece of sawmill equipment we build. You can count on our reliability - year after year.

CALL 603-746-4691



**284 Maple Street
Contoocook, NH 03229**

www.hmccorp.com

Fax: 603-746-4819

info@hmccorp.com